

Trailer Suspensions



20AR/RS3162 DOCKMASTER 2.1 AIR RIDE SLIDER



Innovation. Durability. Low Weight.

The lightest van slider on the market today. Strong enough to stand up to curbing and other abuse. Won't walk or drop away from the dock. Lowest cost of operation. Fewest driver hassles.

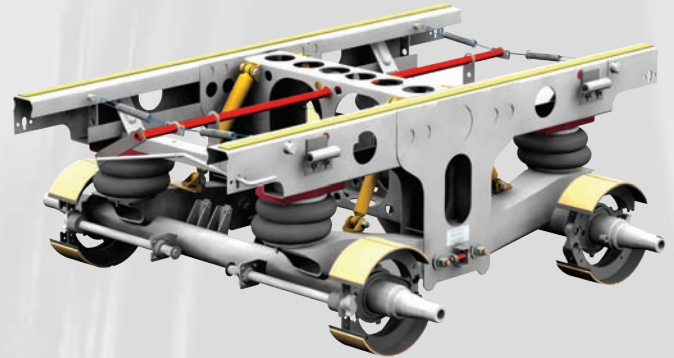

Features

Safe

- No dock walk and no dock drop by design, without complicated add-ons. Our anti-dock drop and anti-dock walk solution not only means less risk of injury to the fork truck driver but also less damage to the load

Lowest Cost of Operation

- No extra parts means less complication and lower cost of repair
- No expensive add-ons, includes standard features that others charge for
- Low weight allows you to haul more freight and save on fuel costs
- Durable construction for longer life and longer trade cycles

Fewest Hassles

- Rey-Align®, true one-person slider alignment
- Flexi-Pull pin release system provides less hassle, less effort, and greater operator safety
- No dump valves

Durable Construction

- Lasts well beyond the most extended trailer-trade cycle
- One center hanger assembly provides ultimate strength, reduces the parts count
- Mid-width trailing beams and 4.5-in. wide pivot bushings reduce weight while giving long life and a better ride
- Double convoluted air springs give a comfortable ride and superior roll stability

Applications

All standard heavy duty trailer applications including:

- Dry freight and refrigerated vans



20AR/RS3162 DOCKMASTER 2.1 AIR RIDE SLIDER

Flexi-Pull pin release system provides less hassle, less effort, and greater operator safety

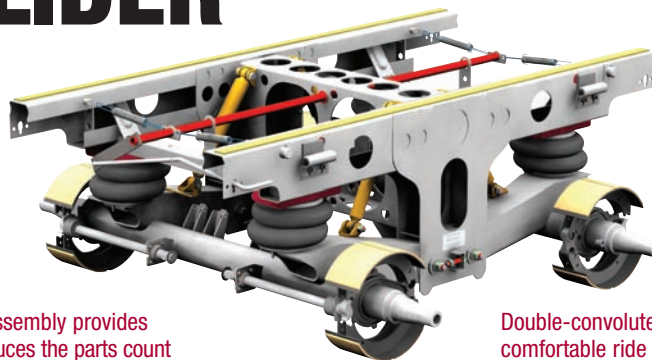

Mid-width trailing beams and 4.5-in. wide pivot bushings reduce weight while giving long life and a better ride

One center hanger assembly provides ultimate strength, reduces the parts count

Double-convoluted air springs give a comfortable ride and superior roll stability

Specifications

Standard

- Anti-dock walk design
- Weight: starting at under 1,430 lbs.
- 49" axle spacing
- Extended life long S-Cams with extended life brake shoes (20K rated)
- Compatible with Hutch and TTMA/Binkley body rails
- All axles prepped for tire inflation systems. Axle tubes drilled, tapped and plugged
- Integrated axle trailing beam
- 15.5" or 17" mounting heights

- 48.38" subframe width
- 77.5" axle track
- 9" subframe height
- 24.5" or 26" total height

Optional

- MTIS[®] tire inflation system preparation
- P series parallel spindle for improved oil seal performance and bearing life
- Air pin release system
- Hubs and drums

Anti-Walk Design



Reyco Granning eliminates both dock walk and dock drop. While loading and unloading, your trailer stays just where you dropped it. As a result, strain on the landing gear is lessened, fork truck traffic is protected, trailer life is extended, and the risk of damaging cargo is reduced.

The Reyco Granning Promise

For nearly 100 years, the Reyco Granning name has been associated with proven product quality, value, and availability. This focus on QVA has helped fleet owners keep their trucks and trailers running more efficiently and more profitably, mile after mile.

QVA Quality: Providing worry-free reliability
 Value: Exceeding customer expectations
 Availability: Delivering on our promise, on time, every time

Reyco Granning is a brand name of Tuthill Transport Technologies, part of Tuthill Corporation, a privately owned international manufacturing company with more than 3,000 employees and facilities on five continents.

1-800-753-0050
www.reycogranning.com

Reyco Granning
 SUSPENSIONS

more miles. less hassle.