

Trailer Suspensions



86AR SLIDER SERIES



**Industry's Only
Limited
Lifetime
Warranty***

Superior by Design

Low Tire Wear. No Dock Walk. No Dock Drop.

A unique combination of design features and an unbeatable track record of over a decade on fleets nationwide, have made the 86AR Slider Series the most reliable and affordable trailer suspensions available.

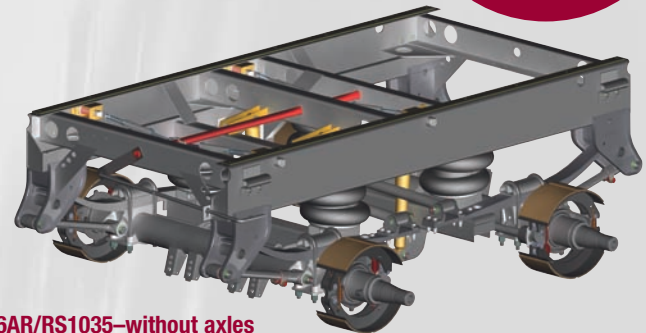

86AR/RS1035—without axles
86AR/RS3035—with Reyco Granning Global Axles™

Features

Superior Strength, Stability, Savings

- Durable, high tensile steel construction maximizes payloads
- Vertically mounted shocks, double-convoluted air bags, and wide spring beam centers provide greater stability
- A four-lock pin setup that can be configured for use with any body rails
- A limited lifetime warranty*

Low Tire Wear

- A patented track-rod design that reduces side-to-side sway, ensuring a longer service life and improved tire life
- Vertical shock absorber placement that offers a counter balance to tough road conditions, which can eat treads alive
- Firmer bushings that provide less deflection and greater weight resistance, adding thousands of miles to tire life

Low Maintenance

- An alignment system that uses simple hand tools, which means your shop can make alignment part of your regular preventive maintenance program
- Industry-standard turn-buckle axle alignment, which means no special training or tools are required
- Re-bushing of torque arms is easy and quick, with the lowest cost in the industry
- Industry-standard replacement parts are widely available, which means less downtime and lower cost of repair

Added Safety

- No dock walk and no dock drop by design, without complicated add-ons. Our anti-dock drop and anti-dock walk solution not only means less risk of injury to the fork truck driver but also less damage to the load

Applications

- All standard heavy duty trailer applications including dry freight and refrigerated vans

* For warranty restrictions and more information, visit www.reycogranning.com/lifetimewarranty or call 1-800-753-0050.



86AR SLIDER SERIES

Reducing Tire Wear by Design

A patented track-rod design reduces side-to-side sway, ensuring a longer service life and improved tire life

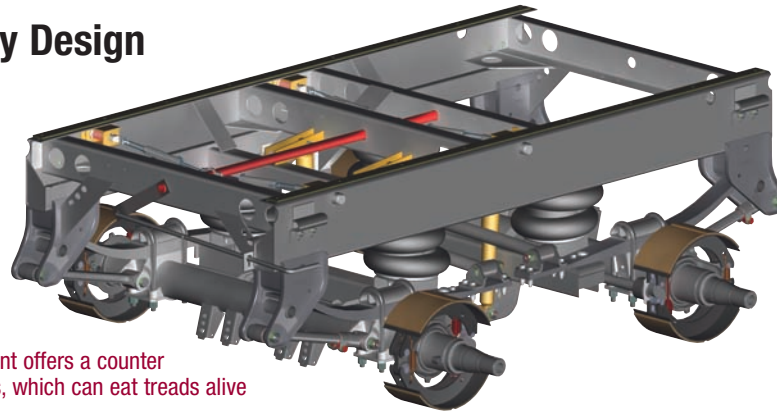

An opposing axle configuration provides increased vehicle stabilization and decreased tread wear

Firmer bushings provide less deflection and greater weight resistance, adding thousands of miles to tire life

Vertical shock absorber placement offers a counter balance to tough road conditions, which can eat treads alive

Specifications

Standard

- Anti-dock walk design
- Slider subframe rated at 44,000 lbs.
- 49" axle spacing

Optional

- Compatible with Hutch or TTMA/Binkley body rails
- 14" to 17 1/2" mounting height in 1/2" increments
- 10" subframe height
- 42" or 48" sub-frame widths
- Optional heavy duty 5 gauge subframe
- Air pin release system

- Factory installed axles (model 86AR/RS3035)
 - Tapered or parallel spindles
 - MTIS® tire inflation system prep (stators installed)
 - 5" round, 1/2" wall, Reyco Granning Global Axles™
 - Extended-life brake shoes
 - All axles prepped for tire inflation systems. Axle tubes drilled, tapped and plugged
 - 48" subframe with 77 1/2" track axles
 - Fully dressed—call for hub and drum options

Limited Lifetime Warranty

- Full coverage for as long as you own the suspension
- Full initial coverage of all parts and labor
 - Replacement parts at 50% off list price
 - Quick delivery of parts shipped direct from Reyco Granning
- No complicated or time consuming claim procedures.
 - After the initial coverage period, claims are made directly to Reyco Granning
 - Simply call our Customer Service department at 1-800-753-0050, provide the model number, in-service date, and shipping instructions

Anti-Walk Design



Reyco Granning eliminates both dock walk and dock drop. While loading and unloading, your trailer stays just where you dropped it. As a result, strain on the landing gear is lessened, fork truck traffic is protected, trailer life is extended, and the risk of damaging cargo is reduced.

The Reyco Granning Promise

For nearly 100 years, the Reyco Granning name has been associated with proven product quality, value, and availability. This focus on QVA has helped fleet owners keep their trucks and trailers running more efficiently and more profitably, mile after mile.

QVA

Quality: Providing worry-free reliability

Value: Exceeding customer expectations

Availability: Delivering on our promise, on time, every time

Reyco Granning is a brand name of Tuthill Transport Technologies, part of Tuthill Corporation, a privately owned international manufacturing company with more than 3,000 employees and facilities on five continents.

1-800-753-0050

www.reycogranning.com

**Reyco
Granning**
S U S P E N S I O N S

more miles. less hassle.