

Trailer Suspensions



LIMITED LIFETIME WARRANTY



86AR/RS3035 Air Ride Slider

Tuthill Transport Technologies (The Company) warrants the Reyco Granning® 86AR/RS3035 suspension manufactured by it to be free from defect in material and workmanship that occurs under normal use, and service, subject to the following conditions and limitations.

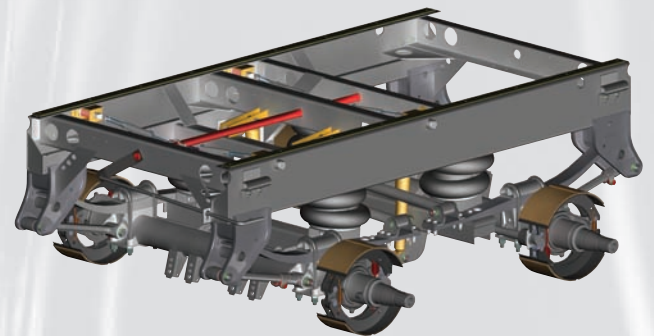

1. Coverage is, per below, in months:

Component	Coverage Period (months)	Coverage Provided
Slider / Suspension	0-60 61+	Parts and labor allowance Limited Lifetime
Axle	0-24 25+	Parts and labor allowance Limited Lifetime
Air Springs	0-24	Parts and labor allowance
Shock Absorbers	0-12	Parts and labor allowance
Bushings	0-24	Parts and labor allowance
Pin Release Components	0-24 25+	Parts and labor allowance Limited Lifetime
Air Controls	0-24 25+	Parts and labor allowance Limited Lifetime

Note: Suspensions used in raw wood or mining applications are not approved and therefore not warranted

Trailer Suspensions



Limited Lifetime Warranty is defined as follows:

After the initial Parts and Labor Allowance coverage shown above, all covered components will be warranted for the life of the suspension when the following conditions are met:

- a. The suspension must be a Reyco Granning 86AR/RS3035 equipped with Reyco Granning Global Axles.
 - b. Replacement parts must be purchased directly from Reyco Granning and shipped direct to claimant.
 - c. The price of such parts will be current published List Price less 50%.
 - d. "Lifetime" coverage applies only to the original purchaser and is not transferable.
2. This warranty shall not apply, and no warranty of any kind shall exist, as to any product which has been subject to abuse, misuse, neglect, misapplication or accident of any type or cause or which has been repaired, replaced, substituted or used with parts other than genuine parts of The Company or has been altered by anyone.
 3. This warranty shall not apply, and no warranty of any kind shall exist, on normal wear and deterioration resulting from the normal use of the suspension system.
 4. The Company shall not be liable for the loss of use of any product, loss of time, inconvenience, commercial loss or any other indirect consequential, special or incidental damages due to breach of the above warranty of any other failure to comply with the terms of the contract between The Company and The Buyer. The Company makes no warranties of any kind, express or implied, other than as herein expressly provided, and specifically disclaims the implied warranties of merchantability and fitness for a particular purpose.
 5. With respect to parts manufactured by others, The Company shall have no duty except to assign to buyer any claim, which The Company may have against the manufacturer thereof. (The Company warrants purchased components to the same extent as the Warranty extended by the original manufacturer to The Company).
 6. This warranty does not apply to the normal "wearing out" of air springs, rubber bushings, shock absorbers, etc., or sacrificial wear areas such as springs to hangers. Also excluded from coverage is damage due to corrosion.
 7. The determination of the reasonable cost of labor as required in paragraph one (1), shall be made in accordance with The Company shop standard times. Maximum hourly allotment for labor cost is determined by The Company annually. Shop standard times and the maximum hourly allotment for labor may be revised periodically at the sole discretion of The Company.
 8. The Company is not responsible for damages from improper installation or operations beyond design capability. The Company, in its sole discretion, shall determine whether or not any product is defective or otherwise covered by this warranty. No action for breach of this warranty may be commenced more than one year after the occurrence of alleged breach. This warranty is not transferable.
 9. Retention of possession or use of the product for the warranty period shall constitute an unconditional acceptance thereof and fulfillment of all warranties and obligations of The Company and no assistance rendered by The Company in operating the product or remedying any defect either before or after that time shall operate to extend the warranty period.

The Reyco Granning Promise

For nearly 100 years, the Reyco Granning name has been associated with proven product quality, value, and availability. This focus on QVA has helped fleet owners keep their trucks and trailers running more efficiently and more profitably, mile after mile.

QVA **Quality:** Providing worry-free reliability
Value: Exceeding customer expectations
Availability: Delivering on our promise, on time, every time

Reyco Granning is a brand name of Tuthill Transport Technologies, part of Tuthill Corporation, a privately owned international manufacturing company with more than 3,000 employees and facilities on five continents.

1-800-753-0050

www.reycogranning.com

War RS3035 Limited Lifetime 11/07/07

PRODUCT INSTALLER RESPONSIBILITIES

10. Installer is responsible for installing the product in accordance with The Company specifications and installation instructions.

Installer is responsible for providing proper vehicle components and attachments, as well as, required or necessary clearance for suspension components, axles, wheels, tires, and other vehicle components to ensure a safe and sound installation and operation.

Installer is responsible for advising the owner of proper use, service and maintenance required by the product and for supplying maintenance and other instruction as readily available from The Company.

PRODUCT OWNER RESPONSIBILITIES

10. Owner is solely responsible for pre-operation inspection, periodic inspections, maintenance, and use of the product as specified by The Company in the particular instructions, available by product model, except as provided in this warranty, and for maintenance of other vehicle components. Of particular importance is the re-torque of fasteners including axle u-bolts, torque arm bolts and track rod bolts. This re-torque must be done within 90 days of the suspension being put in service. Owner is responsible for "down time" expenses, cargo damage, and all business costs and losses resulting from a warrantable failure.

WARRANTY CLAIM PROCEDURES—INITIAL COVERAGE PERIOD

11. For a claim to be considered it must contain adequate documentation which states in-service date of vehicle*, product model, where and how used, and a Reyco Granning Return Material Authorization Number. This claim must be made within 60 days of failure of the component. Such part or parts must be returned to The Company, transportation charges paid. The Company reserves the right to inspect any returned components to determine cause of defects. Coverage is limited to one replacement per component.

WARRANTY CLAIM PROCEDURES—LIMITED LIFETIME COVERAGE PERIOD

12. To make a claim during the Limited Lifetime coverage period, call Reyco Granning (1-800-753-0050). Claimant shall supply the suspension model, in-service date and shipping instructions. Payment, including shipping, must be made at time of claim by Visa or Mastercard.

*In-Service Date is defined as follows:

NEW VEHICLE – license and registration date

AFTERMARKET – date of installation, service invoice

1205 Industrial Park Drive
Mt. Vernon, MO. USA 65712
Toll Free: 800-753-0050
Toll Free Fax: 800-753-1095
Phone: 417-466-2178
Fax: 417-466-3964